

# SPA-9K-100M-50 Solid State Power Amplifier

(9kHz - 100MHz, 50W)

## Key Features

- Multi-octave broadband performance
- High output power
- Wide dynamic range
- High-efficiency GaN technology
- Low power consumption
- Low spurious signal
- Forward/reverse power monitoring
- Extremely load-resistant
- Over voltage, over temperature, over current protection
- Optional overdrive protection
- CE, RoHS certification



## Overview

Saluk SPA-9K-100M-50 is a solid-state RF power amplifier with an output frequency of 9kHz to 100MHz and an output power of 50W. Its design is based on the most advanced LDMOS technology in the industry, and its power output is efficient and reliable. It is mainly used for testing and measuring instruments, Communication or interference, aviation control and other fields. The product has functions such as temperature and current detection, alarm protection and so on.

## Technical Specifications

SPA-9K-100M-50			
<b>Frequency Range</b>	9kHz - 100MHz	<b>Adjustable Gain</b>	20dB (max.)
<b>Output Power</b>	50W (min.)	<b>Input Power</b>	0dBm (max.)
<b>P1dB Output Power</b>	800W (min.)	<b>Harmonic</b>	-10dBc (typ.)
<b>Gain</b>	47dB (min.)	<b>Spurious</b>	-60dBc (max.)
<b>Gain Flatness</b>	± 4dB (max.)	<b>Input VSWR</b>	2.0:1 (max.)

No.367, Fuxing N. Rd.,105 Taipei,Taiwan Tel: +886. 909 602 109

sales@salukitec.com [www.salukitec.com](http://www.salukitec.com)



# SPA-9K-100M-50 Solid State Power Amplifier

(9kHz - 100MHz, 50W)

<b>VSWR Protection</b>	5:1	<b>Impedance</b>	50 ohm
<b>Input Port</b>	N-F, front panel	<b>Output Port</b>	N-F, front panel
<b>Monitoring Port</b>	RS485, LAN	<b>Cooling Type</b>	Air cooling
<b>Communication Interface</b>	LAN	<b>Power Supply</b>	AC 220V±10%, 50/60Hz
<b>Dimension</b>	19", 3U	<b>Operating Temperature</b>	0 - 50°C

## Outline Structure

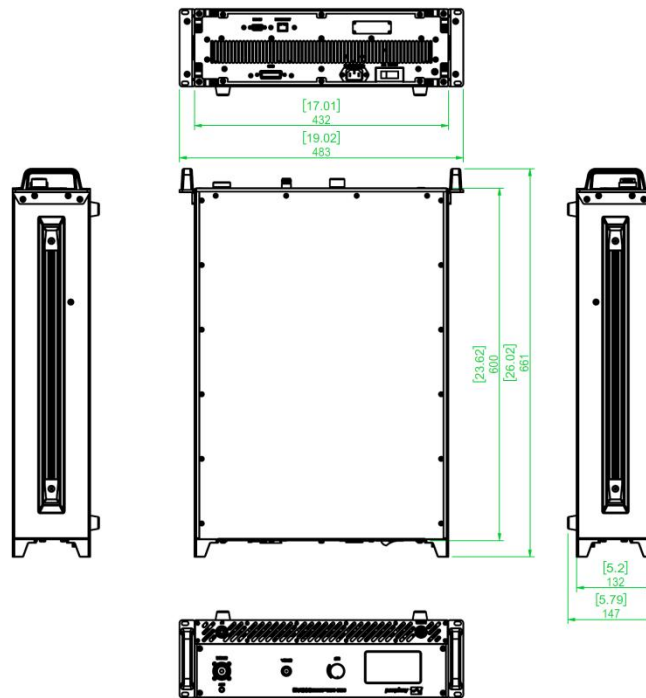

## Options

001	Forward/reverse power monitoring
002	Input power detection
003	GPIB interface

**Note:** Information will conduct the necessary updates, the contents of this document are subject to change without notice.

No.367, Fuxing N. Rd.,105 Taipei,Taiwan Tel: +886. 909 602 109

sales@salukitec.com [www.salukitec.com](http://www.salukitec.com)

